



REMAINS LIGHTING

PERMANENT COLLECTION

NEW YORK • GREENWICH • CHICAGO • LOS ANGELES • LONDON

MARLOWE MIRROR

The sleek, unadorned bronze legs of the Marlowe Mirror join in jewelry-cast unions with clean, expressed domed fasteners. Shown in Satin Nickel.

DIMENSIONS:

OVERALL: 26" H. X 19" W. X 1" D.

MOUNTING TYPE: D RINGS

SPECIFY PORTRAIT OR LANDSCAPE ORIENTATION.

OPTIONS:

Available in additional standard and custom sizes. For other configurations and sizes, see our Marlowe Family.



AVAILABLE FINISHES

polished bronze

burnished nickel, dark waxed bronze, polished nickel, burnished bronze

dark antique bronze, dark pewter, german silver, light antique bronze, light pewter, medium antique bronze, oil rubbed bronze, satin nickel

silverplate

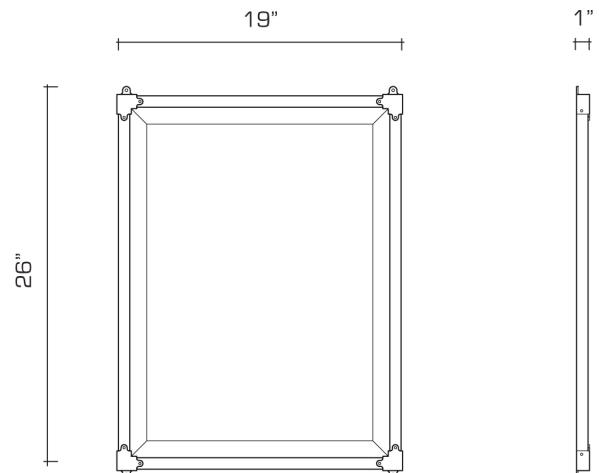

Manufactured using 85% recycled brass